

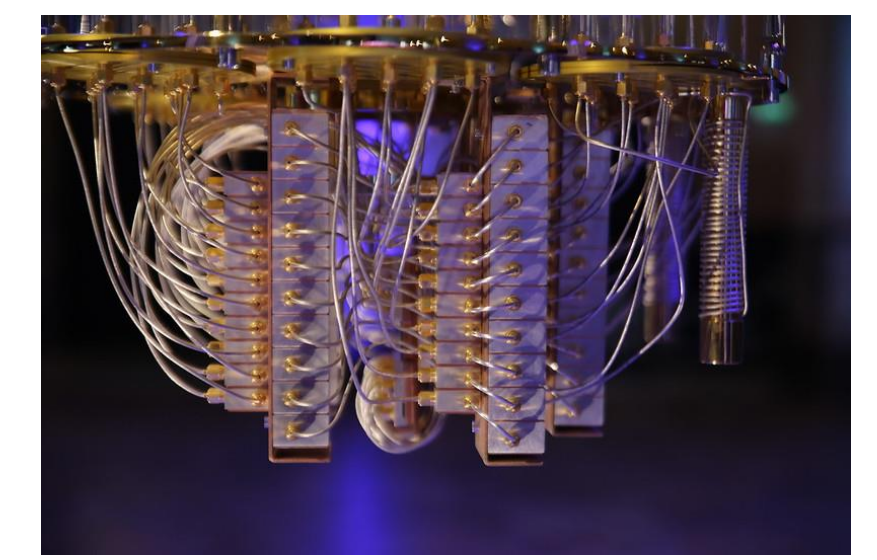

MIDI Generation with Quantum Neural Networks

2025 Quantum Machine Learning REU Program

Ayman Neazi¹, Tanay Patel², Glen Uehara², Gennaro De Luca¹, Andreas Spanias²
¹SCAI, Arizona State University, ²SenSIP Center, ECEE, Arizona State University



RESEARCH BACKGROUND/DESCRIPTION

- Music generation involves extremely complex relationships and patterns between notes.
- Can use machine learning to model these relationships and generate coherent music.
- Try to leverage quantum to express motifs and chords better than previous classical solutions.

LSTM Memory Cell

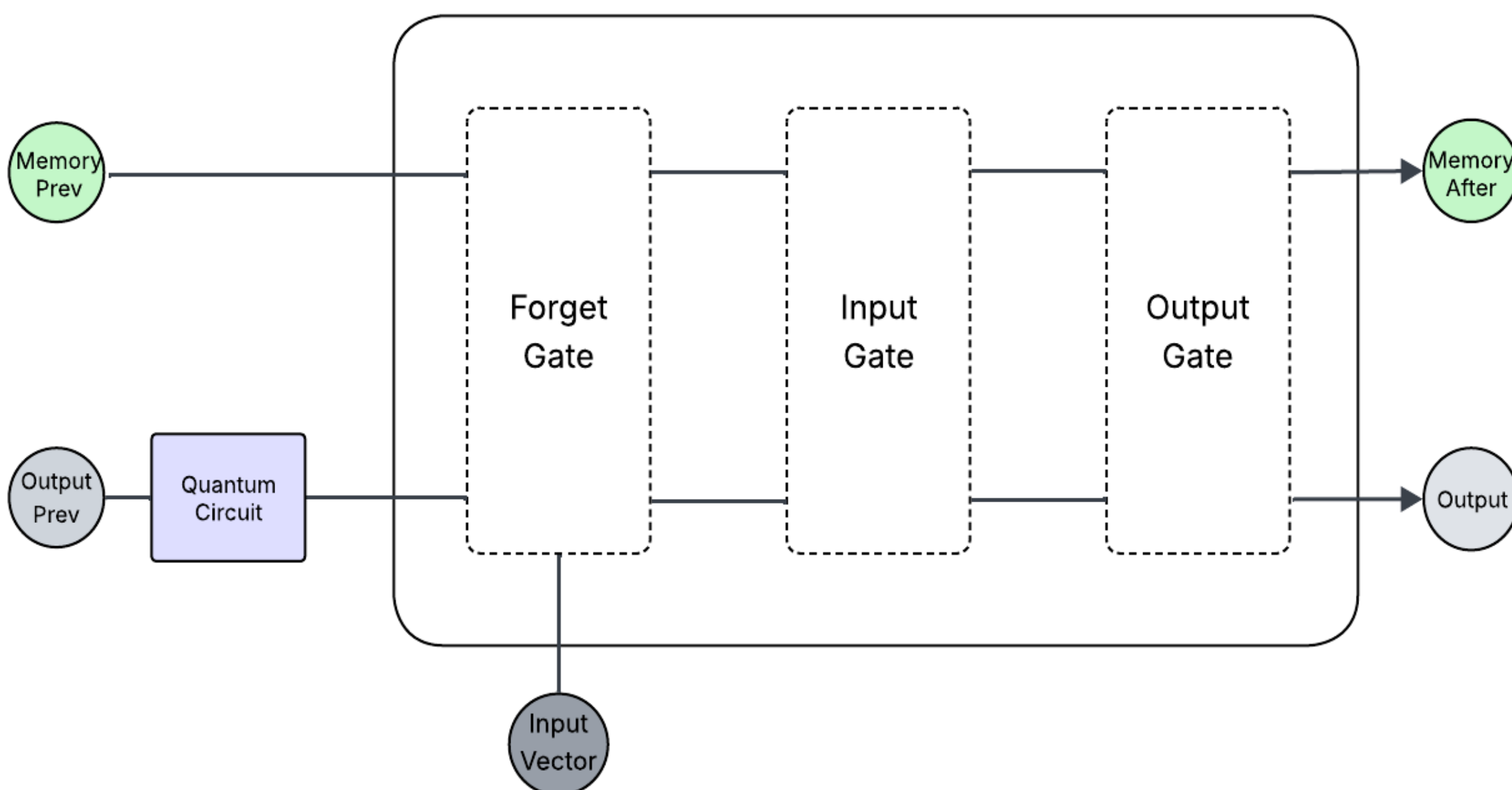

RESEARCH OBJECTIVES/PLAN

- Improve the field of generating music.
- Current generated music is not cohesive and very random [1].
- A quantum LSTM model could potentially predict relationships between notes better [2].

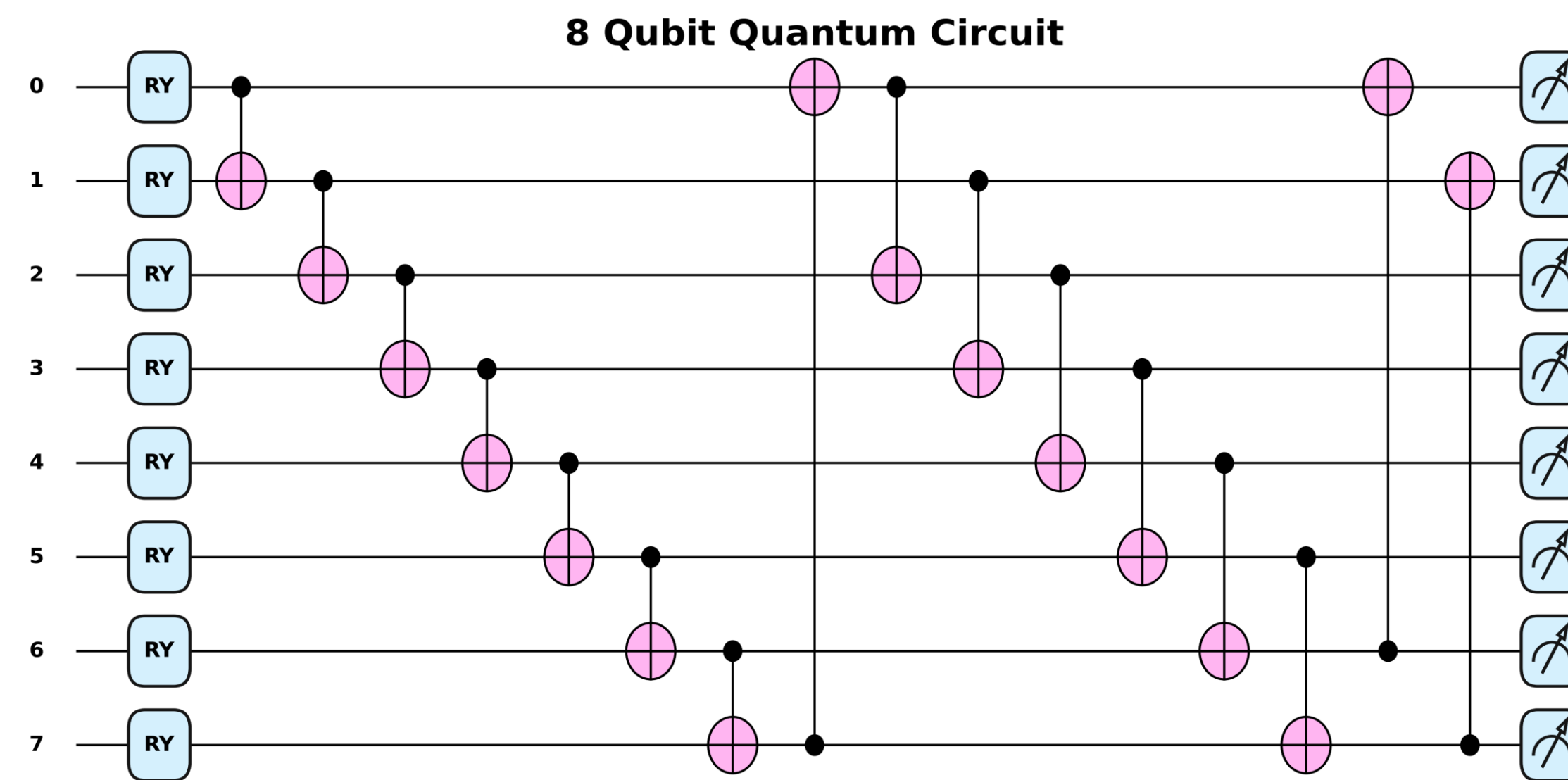

METHODS & MATERIALS

- Pennylane and PyTorch are used for our qLSTM implementation.
- Added a quantum circuit to pass the hidden state through.

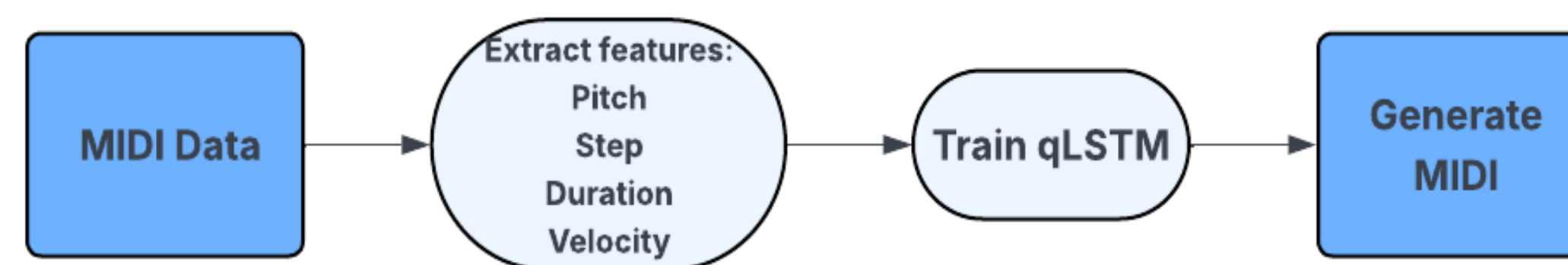

EXPERIMENTAL RESULTS

- Preliminary LSTM results show that the music that is being generated is almost completely random.
- The qLSTM output was the result of 1 file and 50 epochs.

CONCLUSIONS

- It is extremely difficult to train the model on more files as simulation times take long.
- Placement of our quantum circuit may be beneficial in another place such as the memory.
- Finally, the quantum circuit itself may be subject to change.

qLSTM Generated Pianoroll

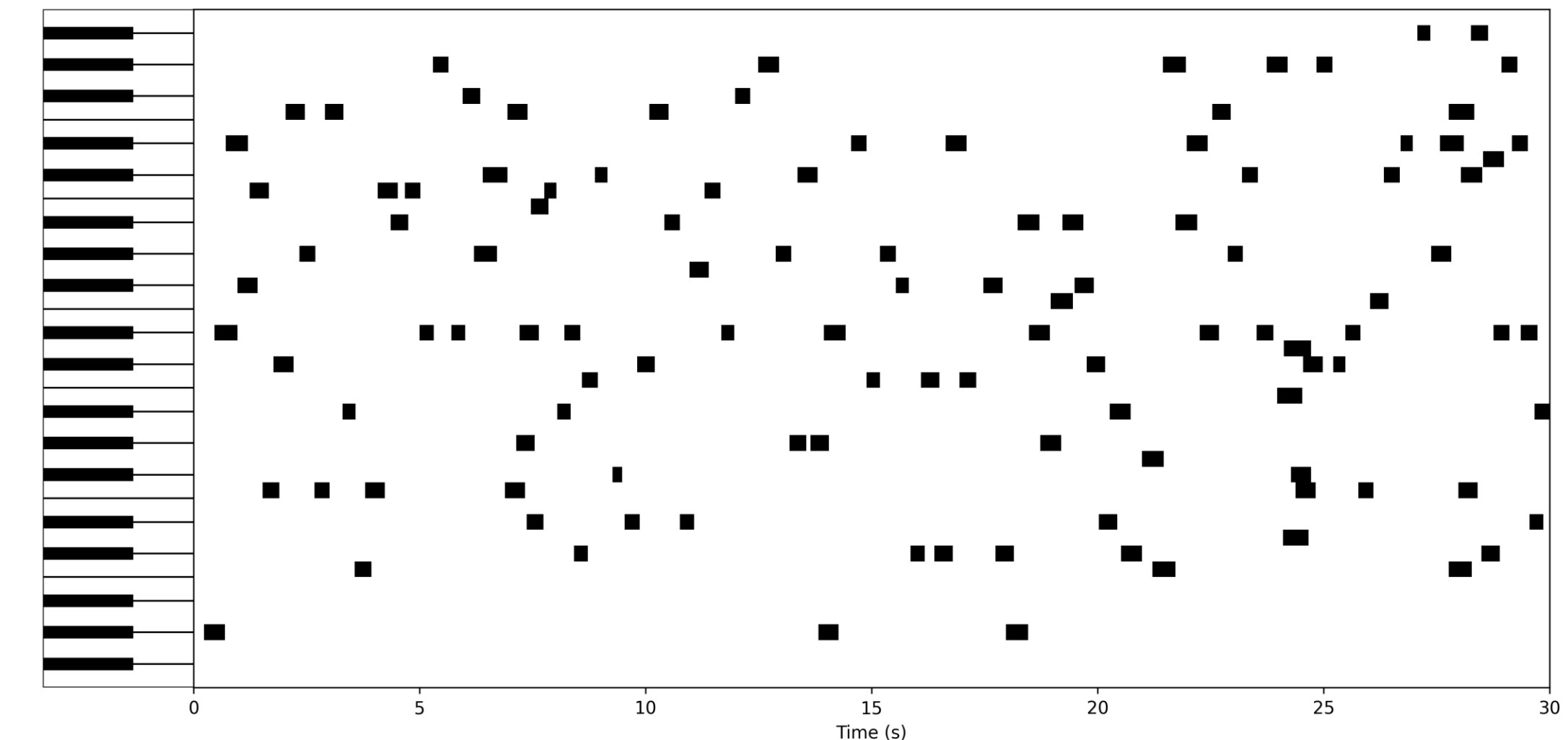

NEXT STEPS

- Improve the current output of the qLSTM to generate more “musical” elements.
- Start looking at how transformers could benefit from this.

REFERENCES

- [1] Walter, S. et al. 2021, May. Midipgan: A progressive gan approach to midi generation. In 2021 IEEE 24th. (CSCWD) (pp. 1166-1171). IEEE..
- [2] Miranda, E.R., 2024. The advent of quantum computer music: mapping the field. Reports on Progress in Physics, 87(8), p.086001.

