

SENSOR SUITE LESSON: DETECTING THE CARBON AND OXYGEN CYCLES

**Karl Ernsberger, Raquel M Diaz, Sritharini Radhakrishnan, Dr. Daniel Gulick, Jennifer Blain
Christen, Ian Akamine**

LESSON DETAILS

Subject Area(s): Local biomes, cellular respiration and CO₂ and O₂ cycles

Focus Grade Level: 10th grade

Grade Level Range: 9th grade - 11th grade

RESEARCH BACKGROUND

Student background:

Students should know:

- Basic cell structure
- Some differences between plants and animals
- Food chains and biome groups

Teacher/Sub Background:

Teacher needs to be familiar with Arduino IDE, Excel or Google Sheets, and Biology.

Research background:

Neonatal sensors currently pick up the 10% most distressed newborns for redirection to NICU. More accurate techniques disrupt the critical social bonding event of skin contact between mother and child and can be invasive. A more accurate and less invasive neonatal sensor array, including CO₂, O₂, pH, glucose, temperature, and heart rate sensors, is needed in order to more clearly identify marginally distressed newborns who need emergency intervention after birth without separating mother and child.

LESSON SUMMARY

Students will use digital sensors to measure pH, ambient CO₂, light and heat to investigate the Oxygen and Carbon cycle interaction between plants and animals. Students will compare CO₂, pH, and other rates over time to determine the minimum plant mass required to fully support a human.

This lesson/project should take two to three weeks, with time for other lessons during data collection.

Possible additional follow up exploration:

- Compare plant growth and CO₂ depletion or O₂ production over time in various initial CO₂ concentrations, soil pH levels, light levels, humidity, etc.
- Compare human CO₂ production at various exertion levels and determine the range of plant mass necessary for various activity levels.

MATERIALS AND EQUIPMENT

Arduino sensors:

[EleGoo Uno Super Starter Kit](#)

[EleGoo Wire Set](#)

[EleGoo 37 Sensor Kit](#)

[pH Sensor](#)

[CO2/air quality Sensor](#)

[Connectors for CO2](#)

[SD Card Datalogger](#)

Container:

large, airtight, with a transparent side or top

Plant:

Any plant that can fit inside the large container

Computer:

Able to run a web browser and Google Sheets or MS Excel, and has an SD chip slot

ATTACHMENTS

These need to be available and set up to run before the lesson begins:

Picture of Arduino circuit:

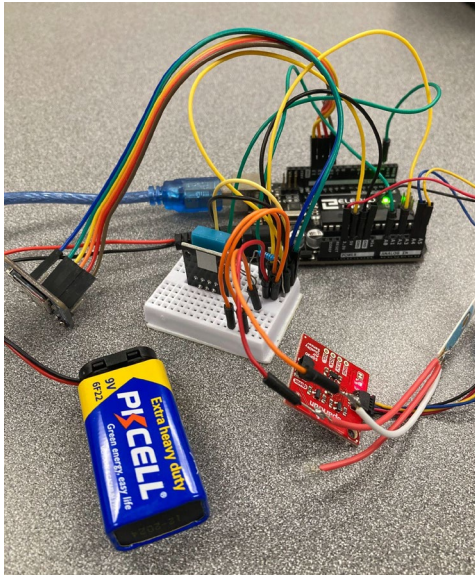
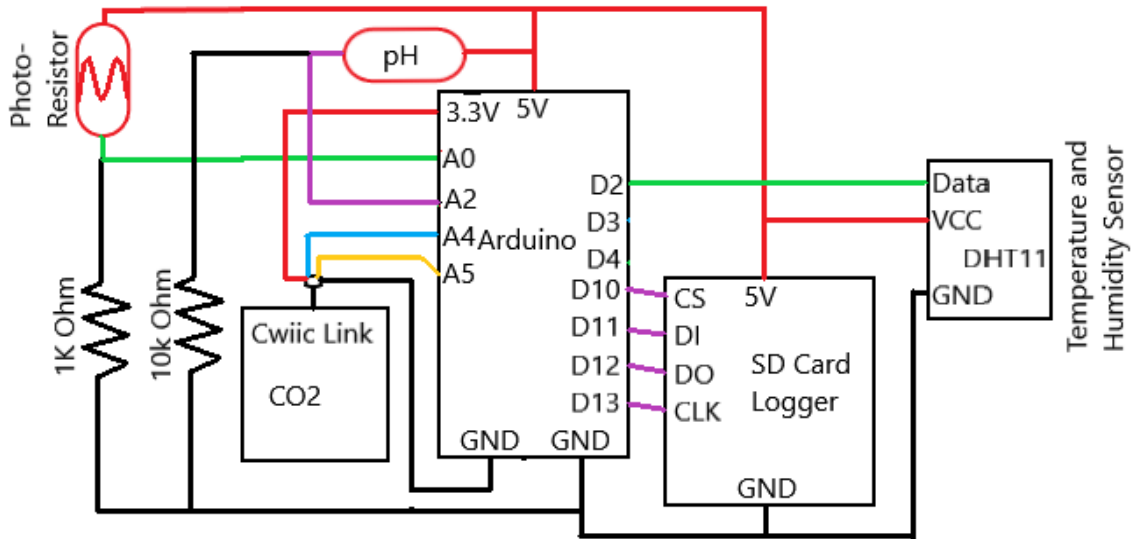

Diagram of Arduino circuit:



Instructions to load Arduino code into circuit:

[Youtube tutorial on running Arduino IDE](#)

Link to the Elegoo code to run the circuit:

[Arduino Elegoo code for capturing the data:](#)

EDUCATIONAL STANDARDS

K-12 TEACHERS

NGSS-HS-LS1-7. Use a model to illustrate that cellular respiration is a chemical process whereby the bonds of food molecules and oxygen molecules are broken and the bonds in new compounds are formed resulting in a net transfer of energy.

NGSS-HS-LS2-3. Construct and revise an explanation based on evidence for the cycling of matter and flow of energy in aerobic and anaerobic conditions.

PO 1. Compare the processes of photosynthesis and cellular respiration in terms of energy flow, reactants, and products. (Grades 9 - 12)

PO 3. Diagram the following biogeochemical cycles in an ecosystem:

- water
- oxygen
- carbon
- nitrogen

LEARNING OBJECTIVES

Students will be able to correlate the CO₂ consumption rate of autotrophs and the animal carrying capacity in a biome.

Students will be able to correlate CO₂ concentration and pH in an aquatic environment

Students will be able to use sensors and observations to measure and compare CO₂ production and consumption rates for autotrophs and heterotrophs in different situations.

VOCABULARY

<i>vocab word/phrase</i>	<i>Definition</i>
autotroph	A species that makes its own food from the sun or other direct energy sources (like thermal vent heat).
heterotroph	A species that gets its fuel from other species.
carrying capacity	How many of a certain species an area can keep alive for a long period of time
biome	Piece of land (or water) that has a matching set of species across the whole area. Desert is a different biome from jungle, for example.
O₂	Oxygen diatomic molecule, normally a gas. This is the kind you breathe in, and plants breathe out.
CO₂	Carbon Dioxide, also normally a gas. This is the kind you breathe out, and plants breathe in.
aquatic	“In the water”
cellular respiration	The kind of material trading individual cells do. This does NOT involve the lungs; the cells take in fuel and oxygen directly from the blood or sap and put waste directly into the blood or sap.
pH	A system of measuring how acidic (or basic) a liquid is. Generally, a 7 is neutral, lower numbers are called acids, and higher numbers are called bases.
Nutrient Cycle	The pattern of exchange of materials between species or locations in a closed system. For example, the water cycle on earth moves water up through the air to mountains, and back down to the sea, but (almost) no water is lost to space.
Correlation	How closely patterns between two variables relate to each other.
Causation	How one variable influences another.

LESSON PROCEDURE

INTRODUCTION/MOTIVATION

Share experience over summer, including weekly update slideshows.

Talk about how sensors work, and where sensors are used (phone, house safety systems, car system, etc.)

Note: teacher should have circuit setup and program running for demonstration.

Show Elegoo sensor setup, and demonstrate how the values in the computer readout change by breathing on the sensors, tapping the light sensor, etc.

Introduce the project scenario: “We are going to mars! We are going to start a Mars colony, and because agriculture will be used to feed people, we will also use plants to provide our oxygen. So, the question for our project is: how many plants will we need to grow on Mars for each person to breathe?”

(Show this [Martian movie clip](#))

Students can look up or guess the answers to these questions. Discuss as a class:

How much air do you breathe in a day? (2000 gallons)

Where are most of the plants in the world? (on land, 70% by mass)

Where is most of the Oxygen coming from? (the ocean, between 50 and 80%)

How does the number of animals vs plants affect the pH of the air, soil, and water? (higher CO₂->more acid pH)

How much CO₂ do you make in a day? (2.3 lbs/day average person-day)

Core project question; they will answer this through the experiment.

How many plants would you need to provide your daily Oxygen use while on Mars?

LEARNING ACTIVITIES/STRATEGIES

Complete introduction above, especially the last question “How many plants would you need to breathe from on Mars?”

Break students into even groups, based on the number of available sensor packs.

Have students connect sensor packs to school laptops, open the Arduino code provided, and check that the sensors are sending data. Give them some time (maybe 15 minutes) to play with the sensors, so they can become familiar with the setup, and understand the meaning of the values recorded by the sensors.

Have the groups designate the following roles:

Experiment runner (set up the plant and sensors, including building the plant enclosure.)

Data collector (gather the data into an excel spreadsheet and provide it to the analyst)

Data analyst (read and interpret the data to find the answer)

Report writer (uses the group’s feedback to complete the report rubric, see below)

To get the experiment started, you will need to assemble (or have the students help you assemble) the Elegoo circuit to match the diagram above. You will also need to start the code linked above using the [Arduino IDE](#). If the IDE is installed (it should already be installed on my work computer), simply double click to open the code given above, plug in the Elegoo to the computer, click the check mark to make sure the code is ready, then click the right-arrow next to the check mark to start the program on the Arduino. If the Port error shows, click “Tools”, then “Port”, then click on whichever port is labeled “Arduino”. Click upload again, and it should work.

Experiment steps:

The **experiment runner** needs to design a box or enclosure of some kind that can hold a plant and the sensor, let light in, but not let air in or out. The sensor needs to be able to send data to a computer continuously during the experiment. The computer does not need to be inside the enclosure. It can help the sensor if the experiment runner breathes into the container just before closing the lid, so there’s extra CO₂ in the box for the sensor and for the plant.

With the plant and sensor inside, run the Elegoo/Arduino code to gather data on: CO₂, light, pH(?), humidity, and temperature. This may need to run for several days to be able to detect a change in the CO₂ levels. The **data collector** needs to make sure the sensor is sending data to the SD card to get used later. Be prepared to leave the code running, or to run periodically for several days. Once the experiment is finished, the data collector needs to take the Plant.exe file [out of the SD card](#) and send it to the Data Analyst. Other class lessons may occur during this stage.

Once the data is collected, and a CO₂ change is clearly evident, the **data analyst** needs to study the data to find out how much CO₂ the plant consumed in the time frame, and what conditions (light, humidity, etc.) changed how fast the plant consumed CO₂. One recommended step is to [open the .txt file](#) in either Excel or Google Sheets, click on one column label (A through G) and [click “Insert” and “Chart”](#) to see the data for that column in a graph. All these

factors need to be used to determine how many of that kind of plant would be needed to supply breathing oxygen for one person.

The **report writer** then takes the analyst’s answer, the data collector’s data, the experiment runner’s design, and uses all that information to write their report/make their poster/type up their presentation. The product needs to include these items:

Rubric: Ten points for each item that must be included in the final presentation.

State the project goal					
Describe the lab setup (plant, box, etc.)					
Put a picture of your plant and sensor and box					
Paste a raw data sample (minimum ten lines)					
Include a labeled chart of the whole dataset					
Write out how you calculated the answer					
Explain what factors could change the answer					
Restate the answer to the question					

CLOSURE

Well done!

I enjoyed all the challenges you encountered, all the variables you brought up, and all the new directions you took on this. Even when I was designing this project, I didn’t know that your discoveries would go as many places as they did.

How well did you anticipate the roadblocks and discoveries on the way?

How did you decide what to do for the experiment?

When you learned of a new variable, what did you do to adapt?

These unanticipated changes along the way are some of the most important events in the course of science. They’re the source of whole new fields, new careers, new technologies, new opportunities. Well done.

ASSESSMENT

FORMATIVE ASSESSMENT

Guiding questions will remind students of the activity sequence and find trouble areas in completing the final product. Drafts and developing products and procedures in process will be observed to assess understanding and creative development of the task.

During instruction, I normally use a “fist to five” student feedback, where I ask them to report individually on confidently they can use the information given with the number of fingers they hold up; “fist” is no confidence, “five” is “I could teach that better than you, Mr. E”, and two’s or threes are always followed up with “ok, ask me a question”. IF the room is 0’s and 1’s, I’ll go back and either demonstrate, scaffold, or adjust the assignment.

SUMMATIVE ASSESSMENT

Rubric: Ten points for each item that must be included in the final presentation.

State the project goal					
Describe the lab setup (plant, box, etc.)					
Put a picture of your plant and sensor and box					
Paste a raw data sample (minimum ten lines)					
Include a labeled chart of the whole dataset					
Write out how you calculated the answer					
Explain what factors could change the answer					
Restate the answer to the question					

CONTRIBUTORS

INDIVIDUALS

Raquel M. Diaz

Sritharini Radhakrishnan

Daniel Gulick

Dr. Jennifer Blain Christen

SUPPORTING PROGRAM

RET Site: Sensor, Signal and Information Processing Algorithms and Software

Sensor, Signal and Information Processing Center (SenSIP), in partnership with Arizona State University and the National Science Foundation.

FUNDING ACKNOWLEDGEMENTS

This project is funded by the National Science Foundation (NSF) Award 1953745. Any opinions, findings, conclusions, or recommendations expressed in this material are those of the author(s) and do not necessarily reflect those of the NSF.